

# Hale Hamilton

Hale Hamilton has been manufacturing high quality valves since 1947. We make high-pressure gas handling equipment for specialist gas producers and users, for power generation, for semiconductor manufacture and for offshore. We also supply compressed air power systems for military use. We are based in Uxbridge approximately 5 miles from London's Heathrow Airport. All our products are designed and manufactured here using state of the art facilities and techniques. We also have offices in Germany and Singapore, which offer full product support and repair facilities.



The Ultra-high-purity cylinder valve is a new product from an established company. We are fully dedicated to supporting this product with special manufacturing facilities (described in this booklet), with extensive qualification testing and with 100% manufacturing testing.

Variants of the cylinder valve are available for the majority of specialist gases with appropriate inlet and outlet connections for all market sectors. All types can be supplied either for manual operation, with a handwheel, or with a pneumatically operated actuator. The actuator can be retro-fitted to a manually operated valve, if required.

For more detailed information please contact us at the address below. Data sheets and full supporting documentation for our qualification tests are available on request.

Hale Hamilton (Valves) Limited, Cowley Road, Uxbridge, Middlesex, UB8 2AF, England  
 Phone: +44 1895 236525, Fax +44 1895 231407 Registered at above address No. 1563775  
 e-mail: [indsales@halehamilton.com](mailto:indsales@halehamilton.com) web-site: [www.halehamilton.com](http://www.halehamilton.com)

# Hale Hamilton

Design and manufacture of high performance cylinder valves for high purity specialist gas applications

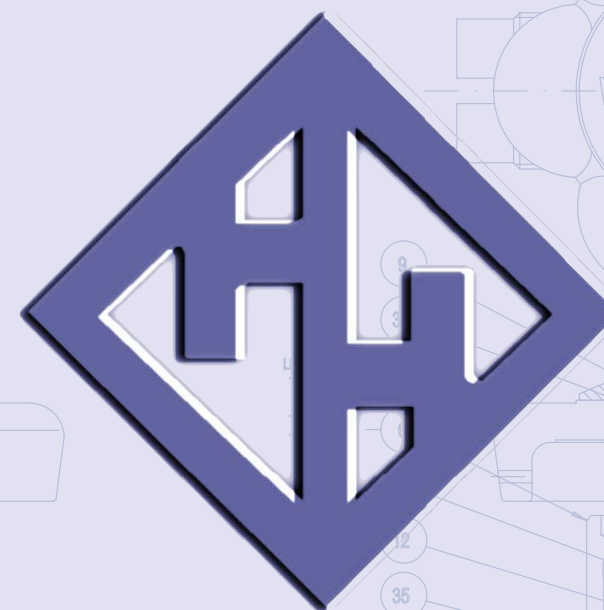

**INTRODUCING THE HALE HAMILTON  
 HIGH PERFORMANCE  
 CYLINDER  
 VALVE**

EXCELLENCE IN FLUID CONTROL

CYLINDER VALVE  
 NB51421SHT01



## UHP600 ultra-high-purity diaphragm cylinder valve

BOC Edwards and Hale Hamilton Valves Ltd have jointly developed an ultra high purity diaphragm cylinder valve for the semiconductor industry. The valve will be marketed to all the gas companies that serve the industry.

For detailed technical information please request a data sheet.

### APPLICATIONS

- Suitable for most special gases including variants for oxygen and highly corrosive gases such as chlorine and hydrogen chloride.
- Inlet and outlet port configurations are available to suit all known industry standards.

### CONSTRUCTION

- The non-tied diaphragm acts directly on the seat to close the valve, minimising dead space and wetted area.
- The mechanically supported and retained valve seat eliminates deformation under load and prevents seat lift under reverse flow conditions.
- The inlet is shaped for enhanced gas flow.
- To prevent the shedding of particulate contamination, there are no sliding, rotating or rubbing components in the flow path.

### MANUFACTURING

- Built to ultra high purity standards in a dedicated facility.
- The body is electrochemically polished.
- Final assembly and testing is carried out under class 10 conditions.
- Each valve is tested for leakage using a mass spectrometer.

UHP600 Manually Operated

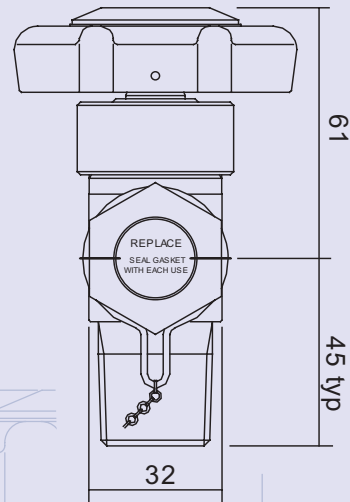

## On Spec and On Time

We know that in today's fast moving industrial climate we all have to respond quickly but we can't compromise on quality.

To achieve this, we have invested in a manufacturing cell dedicated entirely to the quantity production of cylinder valves. This "factory within a factory" allows us to achieve a rapid throughput of valves while maintaining the highest standards of cleanliness and traceability. As well as the processes shown below, the cell has its own controlled stores and production scheduling is independent of the rest of the company.

The benefits to you are:

- Flexible response
- Short lead times
- Reliable delivery
- High Quality
- Complete traceability



ORIENTATION OF DISC SPRING - ITEM 32

## DEDICATED CYLINDER VALVE MANUFACTURING CELL

Assembly in Class 10 laminar flow cabinets in Class 100 Clean Room

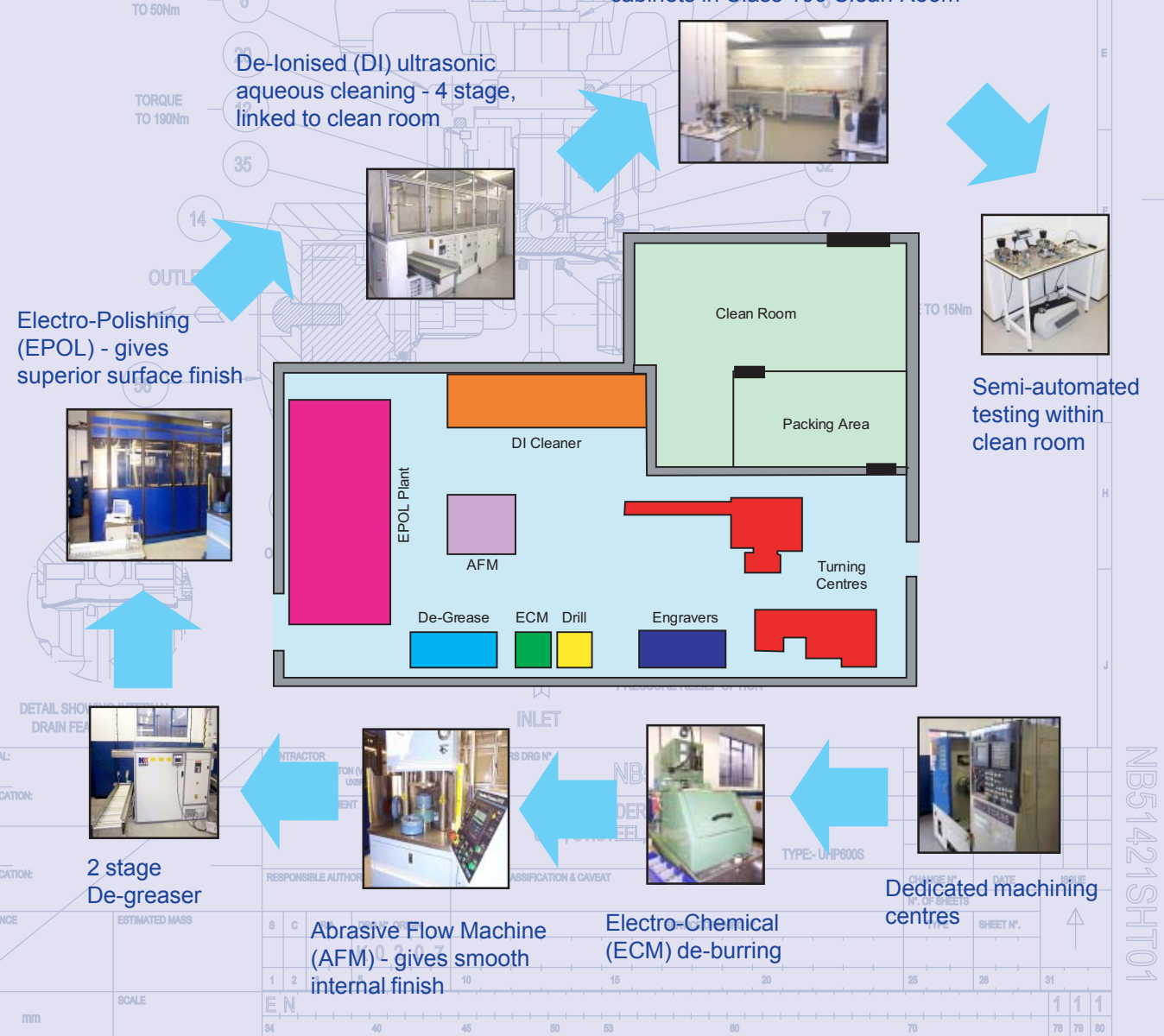

### INDEPENDENT QUALIFICATION TESTING

EN 849-1997:

- External tests to ensure compliance with TPED performed by CTE (Centre de Technologie et d'Expertises - an independent test house accredited to COFRAC)

Vibration tests to MIL-STD-810E:

- Transport simulation to "Category 3 Loose cargo transport protocol" performed by MIRA Ltd.
- Random vibration to "Method 514.4, Category 1, Test Procedure 1" performed by TNO (Netherlands organization for applied scientific research).

Chemical compatibility tests (performed by BOC Edwards):

- Stainless Steel and Hastelloy valves - Chlorine and HCl
- Stainless Steel valves only - Diborane and Silane

Salt Spray test to ISO 9227 for 72 hours (performed by TNO)

Ignition tests:

- Adiabatic compression with oxygen to ISO 10297 "Gas cylinders - Refillable gas cylinder valves - Specification and type testing" performed by CTE
- Nitrous oxide adiabatic compression test to EN849 protocol performed by DNV (Det Norske Veritas)

Air Liquide (R.T.S. C.06.04) "Tests for use with Very Toxic Hydrides and Hydrides Self-Ignitable in Air" (performed by CTE), including:

- Vacuum Conductance Check
- Transport Simulation (Drop) Tests
- Leak Tightness of Secondary Sealing

UHP601 Actuated

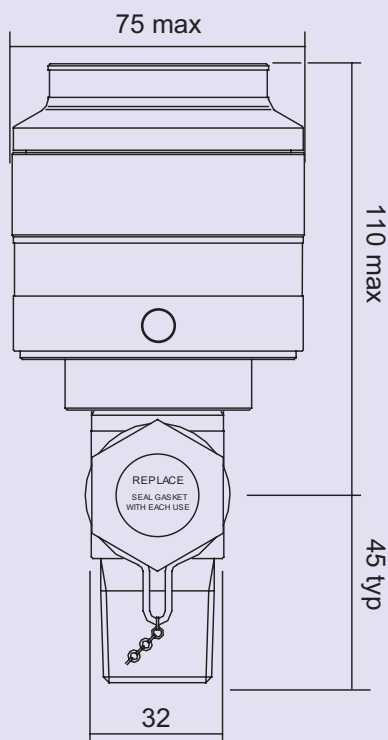

CYLINDER VALVE

NBS1421SHT01